

AUTODESK FUSION 360

2026

# BLOG

 [www.cadin360.com](http://www.cadin360.com)

  
**cadin360°**  
Learning Tutorials

# A Note to Our Readers

2026

This blog has been created using a combination of artificial intelligence tools and human review to help deliver clear, structured, and up-to-date learning content.

All technical topics, examples, and workflows are curated to support learning and skill development. While every effort is made to ensure accuracy and clarity, readers are encouraged to validate concepts through hands-on practice and documentation. Our goal is to make learning more accessible, efficient, and practical for everyone.

## Disclaimer:

All product names, logos, brands, and registered trademarks mentioned in this publication are the property of their respective owners and are used for identification purposes only.

— CADIN360 Team

# HOW TO ASSIGN MATERIAL IN FUSION 360

• LEARN •      • APPLY •      • GROW •

# Introduction

Assigning materials in Fusion 360 is a fundamental step in creating realistic and functional 3D models. Properly applying materials not only enhances visual appearance but also influences the physical properties for simulations and manufacturing. Whether you're designing an industrial part or a simple prototype, knowing how to assign materials efficiently can streamline your workflow and improve your project outcomes. In this comprehensive guide, we'll walk you through the step-by-step process of assigning materials in Fusion 360, share practical tips, common mistakes to avoid, and compare different approaches to ensure you get the most accurate results for your designs.

## Understanding the Importance of Material Assignments in Fusion 360

Before diving into the technical steps, it's useful to understand why assigning materials correctly matters. Proper material assignment impacts:

- **Visual realism:** Accurate textures and colors make your model more convincing.
- **Physical simulations:** Material properties influence stress, thermal, or motion simulations.
- **Manufacturing data:** Proper materials help communicate manufacturing specifications.

Fusion 360 offers a library of predefined materials, enabling designers to simulate real-world behaviors, visualize textures, and prepare files for manufacturing processes efficiently.

Now, let's explore how to assign materials in Fusion 360 with precision and confidence.

## How to Assign Material in Fusion 360: Step-by-Step Guide

### 1. Open Your Fusion 360 Model

Begin by opening your existing project or creating a new design. Make sure your model is fully modeled before assigning materials — it's easier to apply materials after the geometry is

finalized.

## 2. Access the Browser Panel

Locate the **Browser** panel on the left side of the Fusion 360 interface. This panel organizes all components, bodies, sketches, and other elements of your project.

- Ensure the specific component or body you want to assign material to is visible.
- If the Browser panel is hidden, you can enable it by clicking the arrow icon on the left edge.

## 3. Select the Body or Component

Choose the part of your model to which you wish to assign a material:

- **Bodies:** Click directly on the solid body in the canvas or in the Browser.
- **Components:** Select the component in the Browser.
- **Multiple parts:** Use `Shift+click` to select multiple bodies or components simultaneously.

## 4. Open the Material Browser

There are multiple ways to access the material options:

- **Right-click method:**
  - Right-click on the selected body or component.
  - Choose **Properties** from the context menu.
  - Select **Appearance** to open the appearance dialog.
- **Toolbar method:**
  - Click on the **Modify** menu in the toolbar.
  - Select **Appearance** from the dropdown.
- **Shortcut:**
  - Use the keyboard shortcut `A` to open the Appearance dialogue directly.

## 5. Drag and Drop Materials

Within the Appearance dialog:

- Browse the default library categories such as **Metals**, **Plastics**, **Wood**, or **Glass**.
- Select a material that closely matches the real-world counterpart.
- Drag the selected material onto the body or component in the canvas or onto its name in the Appearance dialog.

This direct drag-and-drop method simplifies assigning materials and offers visual feedback immediately.

## 6. Adjust Material Properties (Optional)

Some materials allow customization:

- Double-click on the applied material in the Appearance dialog.
- Adjust specific parameters like color, glossiness, transparency, or texture mapping.
- Confirm when done — this helps match your design specifications more precisely.

## 7. Confirm Your Assignment

Once assigned, click **Close** in the Appearance dialog to apply changes. Your model now visually displays the assigned material, and properties are linked for simulation purposes.

## 8. Save Your Work

Don't forget to save your project to preserve your material assignments. Fusion 360 automatically saves, but it's good practice to manually save after significant modifications.

---

# Practical Examples of Assigning Materials

## Example 1: Assigning Aluminum to an Enclosure

Suppose you're designing an aluminum enclosure:

- Select the enclosure bodies.
- Drag the **Aluminum** material from the library.
- Adjust the color to a light gray for better visualization.
- Use this for both visual rendering and structural analysis.

## Example 2: Applying Rubber for Grip Handles

For rubber grips:

- Select the handle components.
- Pick **Rubber** from the plastics category.
- Increase transparency for a realistic look.
- Use in simulations to analyze grip durability.

---

## Common Mistakes When Assigning Materials and How to Avoid Them

- **Assigning materials to the entire assembly instead of individual parts:**
  - Solution: Select specific bodies or components, not the entire assembly.
- **Not updating the appearance after changing material properties:**
  - Solution: Double-check if the material is correctly dragged onto the correct part.
- **Using incompatible materials for Simulation:**
  - Solution: Confirm if the assigned material properties match simulation requirements.
- **Neglecting to save changes:**
  - Solution: Save your project regularly, especially after major updates.

---

## Pro Tips for Effective Material Assignments in Fusion 360

- Use **material presets** for consistency across projects.
- Utilize **custom materials** for specific project needs, like custom composites.
- Take advantage of **appearance overrides** for specific visual effects without affecting simulation properties.
- For complex textures, consider **adding image textures** for realistic surface detailing.
- Regularly update your material library as Fusion 360's offerings expand.

---

## Comparing Material Assignment Methods in Fusion 360

Method	Ease of Use	Flexibility	Application Scope	Best For
--------	-------------	-------------	-------------------	----------

Drag-and-Drop in Appearance	Very simple	Moderate	Visual and basic use	Quick visual assignments
Material Browser with Drag & Drop	Slightly more detailed	High	Visuals and simulations	Detailed and accurate material assignments

**The drag-and-drop method directly from the appearance library is ideal for most beginners and intermediate users for quick assignments. For more advanced needs, exploring the Material Browser and customizable properties is recommended.**

## Conclusion

Assigning materials in Fusion 360 is a core skill that enhances both the visualization and analysis capabilities of your 3D models. By following a structured approach — selecting the correct bodies, accessing the appearance library, and customizing materials as needed — you can achieve realistic visuals and accurate simulations. Remember to avoid common pitfalls such as misassignments or neglecting to save changes, and leverage the customization options to tailor materials to your project's specific requirements. Mastering material assignment will significantly

elevate your Fusion 360 workflow and the quality of your designs.

## **FAQ**

### **1. How do I assign different materials to separate parts in Fusion 360?**

Ans: Select each part or body individually, then drag and drop the desired material from the Appearance library onto each one.

### **2. Can I customize materials in Fusion 360?**

Ans: Yes, you can modify existing materials by double-clicking them in the Appearance dialog and adjusting parameters like color, texture, or transparency.

### **3. Is it possible to assign materials to assemblies in Fusion 360?**

Ans: While you assign materials at the component or body level, you can also assign materials to the entire assembly by selecting all components and applying a material collectively.

### **4. How do I apply realistic textures in Fusion 360?**

Ans: Use the Appearance dialog to browse texture maps or add custom images to surface materials for realistic surface detailing.

### **5. Can I export material information for manufacturing or rendering?**

Ans: Fusion 360 allows you to include material data in exports like renderings or CAM setups, helping communicate material specifications accurately.

### **6. Are there any shortcuts for assigning materials quickly?**

Ans: The shortcut `A` opens the Appearance dialog, facilitating quick access for material assignment.

## **7. What are some common mistakes to avoid when assigning materials?**

Ans: Common mistakes include applying materials to entire assemblies unintentionally, neglecting to save, and choosing incompatible materials for simulations.

# About CADIN360

2026

CADIN360 Learning Tutorials is an educational platform focused on practical CAD, CAM, and CAE learning.

The platform provides clear, industry-oriented tutorials, design workflows, and real-world insights using tools such as Autodesk Fusion 360.

CADIN360 is created to help learners, students, and professionals build strong fundamentals and practical design skills in modern CAD workflows.

2026

# Practice What You've Learned

You've just completed this blog and learned important concepts in Autodesk Fusion 360.

To help you practice and apply what you've learned, the next pages include a sample from our Fusion 360 book .This sample contains practice exercises and real-world practice tasks designed to strengthen your skills.

## What you'll find next:

- ✓ Practice exercises from the book
- ✓ A brief overview of the complete book
- ✓ Options to explore or request the full sample

**Your hands-on Fusion 360 practice starts next.**

# AUTODESK FUSION 360 ALL IN ONE WORKBOOK

## 500+ PRACTICE EXERCISES

### • Sketching

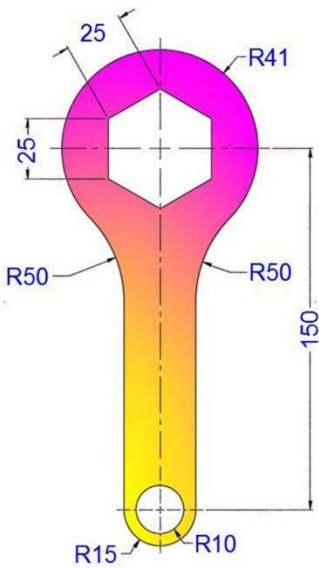

2D Sketching

### • 3D Modeling

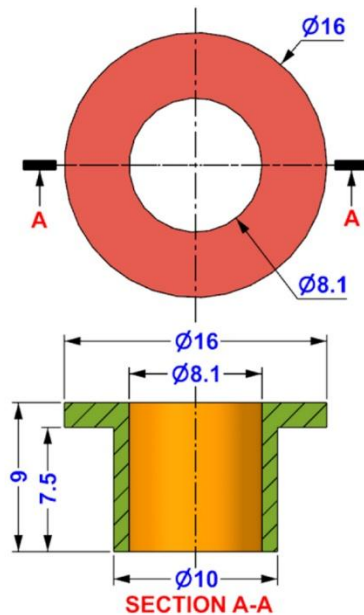

3D Modeling

### • Assembly

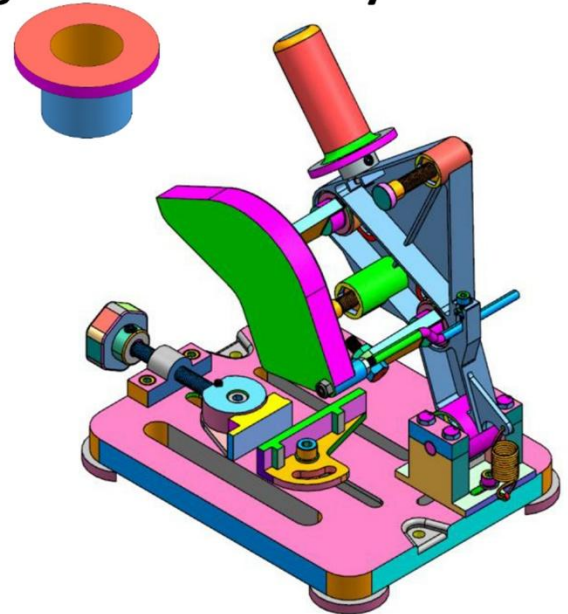

Assembly

SACHIDANAND JHA

**AUTODESK**  
**FUSION 360**  
**ALL IN ONE**  
**WORKBOOK**

500+ PRACTICE EXERCISES

2D Sketching • 3D Modeling • Assembly Drawings

**SACHIDANAND JHA**



Dear Reader,

Thank you for choosing the AUTODESK FUSION 360 ALL IN ONE WORKBOOK. This book is part of the CADIN360° learning series, created to help engineers, students, and professionals master Fusion 360 through structured and practical exercises.

This book contains over 500 carefully crafted practice drawings, including:

- 200 2D Sketching Exercises
- 200 3D Modeling Exercises
- Comprehensive Assembly Models with 150+ Individual Part Drawings

We founded CADIN360 in 2016 with the goal of delivering practical, high-quality learning material for CAD software. More than 9 years later, we're still committed to producing consistently exceptional books. With each of our titles, we're working hard to set a new standard for the industry. From the paper we print on, to the authors we work with, our goal is to bring you the best books available.

I hope you see all that reflected in these pages. I'd be very interested to hear your comments and get your feedback on how we're doing. Feel free to let me know what you think about this or any other CADIN360 book by sending me an email at [cadin360@gmail.com](mailto:cadin360@gmail.com)

If you think you've found a technical error in this book, please visit <https://cadin360.com/contact-us/>.

Customer feedback is critical to our efforts at CADIN360.

Best regards,

Sachidanand Jha  
Founder & CEO, CADIN360



# **AUTODESK FUSION 360 ALL IN ONE WORKBOOK**

Published by CADIN360

Website: [cadin360.com](http://cadin360.com)

Copyright © 2025 by CADIN360, All rights reserved.

This book is copyrighted and the CADIN360 reserves all rights.

No part of this publication may be reproduced, stored in a retrieval system or transmitted, transcribed, stored in retrieval system or translated into any language, in any form or by any means, electronic, mechanical, photocopying, recording, scanning or otherwise, without the prior written permission of the publisher & Author.

## **Limit of Liability/Disclaimer of Warranty:**

The publisher and the author make no representations or warranties with respect to the accuracy or completeness of the contents of this work and specifically disclaim all warranties, including without limitation warranties of fitness for a particular purpose. No warranty may be created or extended by sales or promotional materials. The advice and strategies contained herein may not be suitable for every situation. This work is sold with the understanding that the publisher is not engaged in rendering legal, accounting, or other professional services. If professional assistance is required, the services of a competent professional person should be sought. Neither the publisher nor the author shall be liable for damages arising herefrom. The fact that an organization or Web site is referred to in this work as a citation and/or a potential source of further information does not mean that the author or the publisher endorses the information the organization or Web site may provide or recommendations it may make. Further, readers should be aware that Internet Web sites listed in this work may have changed or disappeared between when this work was written and when it is read.

## **Examination Copies**

Books received as examination copies in any form such as paperback and eBook are for review only and may not be made available for the use of the student. These files may not be transferred to any other party. Resale of examination copies is prohibited

## **Electronic Files & Usage Rights:**

The electronic file/eBook in any form of this book is licensed to the original user only and may not be shared, distributed, resale or transferred to any other party. To access files, the user must contact **[cadin360@gmail.com](mailto:cadin360@gmail.com)** with valid proof of purchase. Unauthorized distribution of the files is a violation of copyright law.

## **Disclaimer:**

All product names, logos, brands, and registered trademarks mentioned in this publication are the property of their respective owners and are used for identification purposes only.

# AUTODESK FUSION 360 ALL IN ONE WORKBOOK

- ❖ This book contains over 500 CAD practice exercises, organized as:
  1. 200 2D Sketching Exercises
  2. 200 3D Modeling Exercises
  3. Assembly Projects with 150+ Part Drawings
- ❖ This book is a practice workbook. It does not include step-by-step tutorials for creating 2D drawing, 3D models and Assembly.
- ❖ SI units (millimeters) are used for all dimensions.
- ❖ Third Angle Projection is used throughout this book.
- ❖ This book is for **AUTODESK FUSION 360** and also suitable for Other Feature-Based Modeling Software such as Inventor, Catia, SolidWorks, NX, Solid Edge, AutoCAD, PTC Creo etc.
- ❖ Designed for students, engineers, drafters, and designers looking for extensive CAD practice using Autodesk Fusion 360.
- ❖ The exercises cover a wide range of real-world modeling challenges—from simple sketches to complex assemblies—offering clear, concise, and structured drawing practice.
- ❖ Exercises are organized to gradually develop beginner to advanced-level design skills.
- ❖ Each exercise is self-contained, and can be completed independently.
- ❖ Assembly drawings follow industry standards to help improve visualization and multi-part modeling skills.
- ❖ All dimensions are in mm. Assume missing dimensions logically.

## HOW TO USE THIS BOOK

This book contains over 500 CAD practice exercises, designed for self-paced learning using Autodesk Fusion 360 or any feature-based modeling software.

- 2D Sketching Exercises: Start here if you're a beginner or learning how to use the sketch environment.
- 3D Modeling Exercises: Follow after mastering sketching. Practice creating solid models using the provided dimensions.
- Assembly Drawings: Use after completing part models to understand multi-part assemblies, relationships, and constraints.

### **Tips for Best Use:**

- Complete the exercises in order, or jump to any skill level you prefer.
- All dimensions are in millimeters.
- Where dimensions are missing, apply logic or practice estimation.
- This book is ideal for both students and professionals preparing for industry design work.

### **Note:**

This book is available in multiple formats – **Black & White**, **Standard Color**, and **Premium Color** editions.

Happy learning!  
– Team CADIN360

3D

## EXERCISE-01

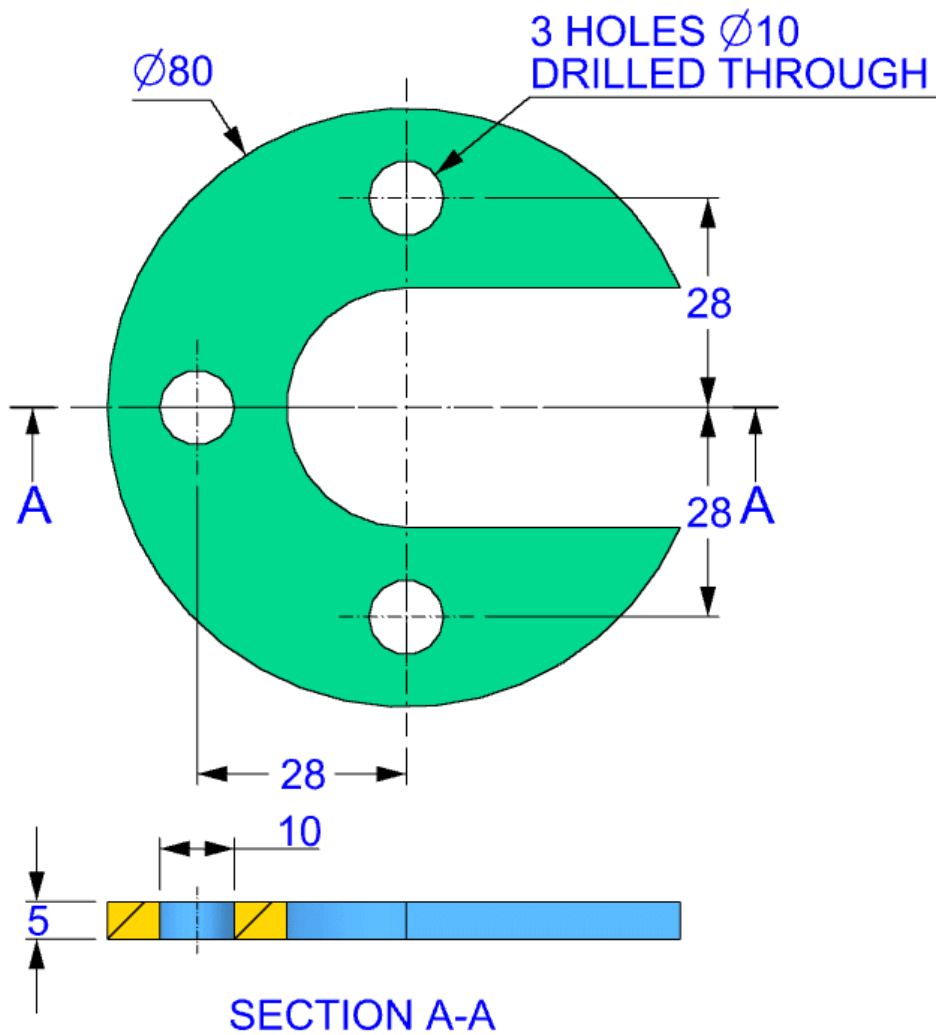
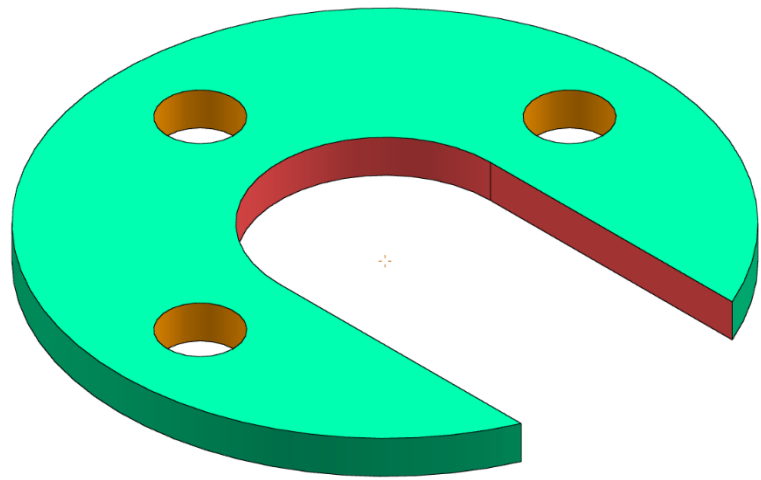

# Get The Complete Practice Sample

You downloaded a single Exercise PDF

The complete practice sample for this software includes multiple exercises and is not available inside this PDF..

## What you will receive

- A software-specific complete sample PDF
- Multiple real practice exercises (not a single file)
- Same quality as our professional training material
- Compatible with the latest software version

## How to get the complete sample

Click the button below and **enter a valid email address**.  
The **complete sample PDF will be delivered automatically**  
after the form is submitted.

**SEND THE COMPLETE SAMPLE TO MY EMAIL**

# END OF SAMPLE

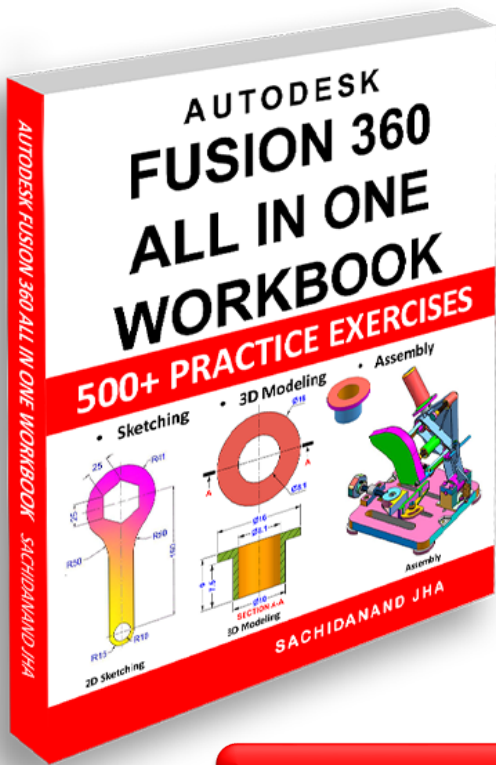

## What's Included in the **FUSION 360 ALL IN ONE WORKBOOK?**

- ✓ Books contains exercises of Sketching, 3D Modeling & Assembly.
- ✓ 500+ Practice Exercises with Dimensions
- ✓ Full Assembly STEP Files (.stp format) – Compatible with all major CAD software
- ✓ Get 200 3D Exercises in .f3d file format
- ✓ Get All Assembly Exercises in .STP file
- ✓ Instant Download Link - Sent to Your Email After Payment
- ✓ Lifetime Access to All Files

**Get the Paperback book on Amazon**

**Get the Complete Bundle for Only \$27.99**

## Special Offer for Students & Learners

Are you a Student, Unemployed or Financially struggling ?  
Get this special Bundle only for \$19.99

***Special Offer for Only \$19.99***



# Thank You for Learning with Us!

Thank you for choosing the **AutoDesk Fusion 360 ALL IN ONE WORKBOOK**. We hope this book helped you strengthen your Fusion 360 skills through hands-on practice and real-world design challenges.

Your feedback means the world to us!

If you found this book helpful, please take a moment to leave a **review** on the Amazon where you purchased it. Your kind words not only motivate us but also help other learners discover our resources. Scan the QR.

★ A good review goes a long way!

## 📖 Explore More CAD Practice Books

Looking to continue your learning journey?

We offer similar practice-based books for over **30 CAD software platforms**, including:

- AutoCAD
- SolidWorks
- FreeCAD
- TinkerCAD
- TurboCAD
- Siemens NX
- CATIA
- Creo
- SketchUp and many more...

Visit our website 🖱️ [www.cadin360.com](http://www.cadin360.com) to browse the complete collection.

## 💬 Stay Connected

Have suggestions, feedback, or just want to say hello?

We'd love to hear from you!

✉️ Email: [cadin360@gmail.com](mailto:cadin360@gmail.com)

🌐 Website: [www.cadin360.com](http://www.cadin360.com)

## 🚀 Keep Practicing. Keep Designing.

Whether you're a beginner or a pro, **practice is the key** to mastering any CAD software.

We're honored to be a part of your journey.

**Happy Designing!**

– Team **Cadin360**



# Master Fusion 360 with Real-World Practice Exercises

This book contains over 500 Fusion 360 practice exercises including sketching, 3D modeling, and assembly drawings.

Designed for students, engineers, and professionals to build practical CAD modeling skills.

## **AUTODESK FUSION 360 ALL IN ONE WORKBOOK**

### **This book contains:-**

- 200 2D Sketching Exercises
- 200 3D Modeling Exercises
- Multi-part Assembly Exercises & Detailed Drawings
- All drawings in 3<sup>rd</sup> Angle projection
- All dimensions are in mm(metric system)