

AUTODESK FUSION 360

2026

BLOG

A Note to Our Readers

2026

This blog has been created using a combination of artificial intelligence tools and human review to help deliver clear, structured, and up-to-date learning content.

All technical topics, examples, and workflows are curated to support learning and skill development. While every effort is made to ensure accuracy and clarity, readers are encouraged to validate concepts through hands-on practice and documentation. Our goal is to make learning more accessible, efficient, and practical for everyone.

Disclaimer:

All product names, logos, brands, and registered trademarks mentioned in this publication are the property of their respective owners and are used for identification purposes only.

— CADIN360 Team

WHY COMPONENTS ARE IMPORTANT IN FUSION 360

• LEARN • • APPLY • • GROW •

Introduction

In the world of computer-aided design (CAD), Fusion 360 stands out as a versatile and powerful tool used by engineers, hobbyists, and professional designers alike. At the core of creating efficient and manageable designs in Fusion 360 lies the concept of components. Components are foundational building blocks that help organize, control, and streamline your entire design process. Understanding why components are important in Fusion 360 is crucial for maximizing productivity and creating complex, multi-part assemblies with ease. This guide will explore the many reasons components matter, how to use them effectively, and the benefits they bring to your CAD projects.

What Are Components in Fusion 360?

Components in Fusion 360 are individual, distinct parts or assemblies within a larger design. Think of them as the "building blocks" that make up your entire model. Each component can have its own set of features, modifications, and parameters, allowing for flexible, modular design processes. They resemble separate objects that are grouped within an assembly, but unlike simple bodies, components can be fully parametric and independently controlled.

In Fusion 360, components serve as containers for features, sketches, and bodies. They are essential for creating complex assemblies, facilitating collaboration, and managing large-scale projects. They enable designers to work on sub-assemblies or individual parts without affecting the overall model until integration.

Why Components Are Important in Fusion 360

1. Organizational Clarity and Manageability

As designs grow in complexity, managing multiple parts becomes a challenge. Components help organize your project hierarchically, keeping your workspace tidy. For example, a complete product like a drone can be broken into components such as the frame, motors, battery pack, and landing gear.

- Components visually group related features.

- They simplify navigation within complex models.
- They prevent chaos in multi-part assemblies.

Using components makes it easier to locate, edit, and troubleshoot specific parts without affecting the entire design.

2. Modular and Reusable Design

One of the most significant advantages of components is reusability. When designing standard parts—such as screws, brackets, or custom housings—you can create a component once and reuse it across multiple projects.

- Reuse enhances efficiency, saving time.
- Changes to the master component automatically update all instances.
- Components can be exported for use in future designs, ensuring consistency.

This modular approach enables rapid iteration and reduces redundant work.

3. Simplified Assembly and Mating

Fusion 360's assembly feature hinges on components. They allow for precise placement, constraining, and mating of different parts, mimicking real-world assembly processes.

- Components are inserted and aligned relative to each other.
- Mates define how parts fit or move in relation to each other.
- Assemblies can be tested for fit, interference, and motion.

This structure enables simulation of how physical parts will interact, a critical part of product development.

4. Independent Parametric Control

Components in Fusion 360 are fully parametric, meaning each can have its own dimensions, constraints, and features.

- Adjust one component independently without affecting others.
- Create variations by changing parameters.
- Maintain consistency across designs by linking parameters.

This independence is vital for iterative design and customization.

5. Facilitates Multi-User Collaboration

In professional environments, multiple designers or teams often collaborate on a single project. Components support this workflow by allowing:

- Clear ownership of parts.
- Controlled editing rights.
- Simultaneous work on different components or sub-assemblies.

This separation reduces conflicts and improves project version control.

6. Supports Design Iteration and Testing

Using components allows for easy modification and testing of different design options:

- Swap out components for alternatives.
- Test prototypes virtually by adjusting parameters.
- Quickly evaluate changes in assembly context.

It leads to faster design validation and iteration cycles.

7. Compatibility with Export and Manufacturing Processes

Manufacturers and CNC software often require individual parts for fabrication. Components simplify this by:

- Exporting parts as separate files for machining or 3D printing.
- Creating detailed assembly instructions.

- Supporting multiple manufacturing workflows within the same design.

This integration streamlines the transition from CAD to production.

How to Use Components Effectively in Fusion 360

Step-by-Step: Creating Components

1. **Start with your bodies or sketches.**
2. **Convert bodies into components:**
 - Select the desired body.
 - Right-click and choose “Create Component” or “Save Body as Component.”
1. **Name and organize each component logically.**

Managing Components in an Assembly

1. **Insert components into your design workspace:**
 - Use the “Create” menu or drag-and-drop from the Browser.
1. **Position components using the move or align tools.**
2. **Apply joints and mates to define their relationships.**

Best Practices

- Use meaningful names for components for easier navigation.
- Keep components small and modular; avoid overloading a single component.
- Use component sketches for defining interfaces and mounting points.
- Regularly check for interference or collisions in assemblies.

Common Mistakes to Avoid

- Creating all geometry in a single component—splitting into multiple reduces flexibility.
- Forgetting to update instances when modifying components.
- Over-reliance on rigid components without considering movement or assembly constraints.

Practical Example: Designing a Custom Gearbox

Suppose you're designing a gear-driven mechanism. Here's how components streamline this process:

1. **Create separate components: housing, gears, shafts, fasteners.**
2. **Design each as individual, reusable components.**
3. **Assemble by inserting components and defining mates.**
4. **Adjust gear sizes or shaft lengths by modifying individual components.**

This modular approach simplifies testing different gear ratios or housing designs without rebuilding the entire model.

Comparison: Components vs. Bodies in Fusion 360

Feature	Bodies	Components
---------	--------	------------

Hierarchical Structure	Flat, single level	Organized in a hierarchy
Reusability	Limited to current file	Reusable across projects
Assembly Support	No (for assembly, use joints)	Fully supports assemblies
Parametric Independence	Not independent	Fully independent
Collaboration	Limited in multi-user scenarios	Facilitates collaboration

Modifications	Affect only current body	Can be independently modified
---------------	--------------------------	-------------------------------

In summary, while bodies are basic geometry, components add structure, reusability, and assembly control—making them fundamental to successful Fusion 360 workflows.

Conclusion

Components are the backbone of effective design in Fusion 360. They bring clarity to complex projects, enable modularity and reuse, simplify assembly and mating, support multi-user collaboration, and improve overall workflow efficiency. By mastering their use, you unlock the full potential of Fusion 360 to create intricate, manageable, and manufacturable designs with confidence. Whether you're crafting a simple part or developing an advanced multi-component product, understanding why components are important is essential to your success in CAD design.

FAQ

1. Why should I use components instead of just bodies in Fusion 360?

Ans : Components provide organization, reusability, and assembly support, whereas bodies are simple geometry without hierarchical structure.

2. Can I convert bodies into components after creating them?

Ans : Yes, right-click on a body and select "Create Component" or "Save Body as Component" to convert it.

3. How do components improve collaboration in Fusion 360?

Ans : They enable multiple users to work on different parts independently, reducing conflicts and making version control easier.

4. Is it possible to reuse components across different projects in Fusion 360?

Ans : Yes, components can be exported and imported into other projects, promoting reusability.

5. How do components help in designing assemblies?

Ans : They allow precise placement, mating, and simulation of parts to ensure proper fit and function.

6. What is the best way to organize large assemblies in Fusion 360?

Ans : Use multiple components with clear naming, hierarchical organization, and proper mating strategies to manage complexity.

7. Can I update all instances of a component if I make changes to the master level?

Ans : Yes, changes made to the master component automatically update all instances unless they are overridden individually.

About CADIN360

2026

CADIN360 Learning Tutorials is an educational platform focused on practical CAD, CAM, and CAE learning.

The platform provides clear, industry-oriented tutorials, design workflows, and real-world insights using tools such as Autodesk Fusion 360.

CADIN360 is created to help learners, students, and professionals build strong fundamentals and practical design skills in modern CAD workflows.

Practice What You've Learned

2026

You've just completed this blog and learned important concepts in Autodesk Fusion 360.

To help you practice and apply what you've learned, the next pages include a sample from our Fusion 360 book .This sample contains practice exercises and real-world practice tasks designed to strengthen your skills.

What you'll find next:

- ✓ Practice exercises from the book
- ✓ A brief overview of the complete book
- ✓ Options to explore or request the full sample

Your hands-on Fusion 360 practice starts next.

AUTODESK FUSION 360 ALL IN ONE WORKBOOK

500+ PRACTICE EXERCISES

• Sketching

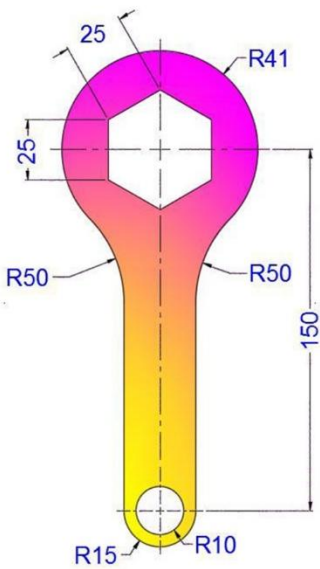

2D Sketching

• 3D Modeling

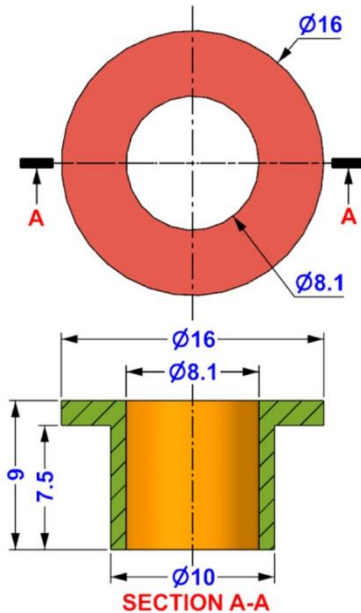

3D Modeling

• Assembly

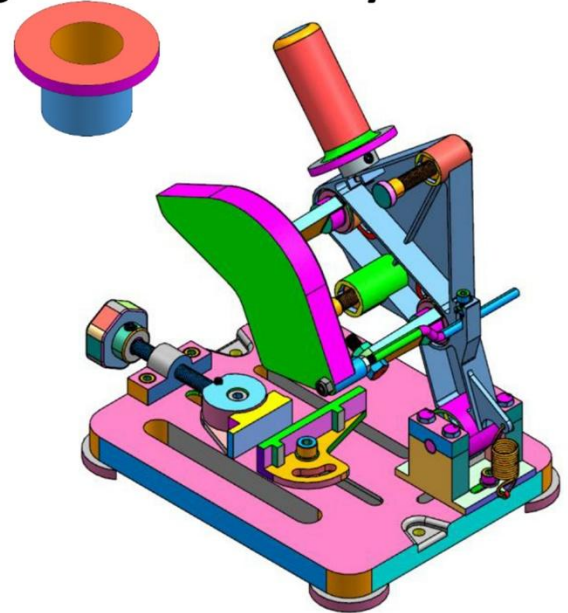

Assembly

SACHIDANAND JHA

AUTODESK FUSION 360 ALL IN ONE WORKBOOK

500+ PRACTICE EXERCISES

2D Sketching • 3D Modeling • Assembly Drawings

SACHIDANAND JHA



Dear Reader,

Thank you for choosing the AUTODESK FUSION 360 ALL IN ONE WORKBOOK. This book is part of the CADIN360° learning series, created to help engineers, students, and professionals master Fusion 360 through structured and practical exercises.

This book contains over 500 carefully crafted practice drawings, including:

- 200 2D Sketching Exercises
- 200 3D Modeling Exercises
- Comprehensive Assembly Models with 150+ Individual Part Drawings

We founded CADIN360 in 2016 with the goal of delivering practical, high-quality learning material for CAD software. More than 9 years later, we're still committed to producing consistently exceptional books. With each of our titles, we're working hard to set a new standard for the industry. From the paper we print on, to the authors we work with, our goal is to bring you the best books available.

I hope you see all that reflected in these pages. I'd be very interested to hear your comments and get your feedback on how we're doing. Feel free to let me know what you think about this or any other CADIN360 book by sending me an email at cadin360@gmail.com

If you think you've found a technical error in this book, please visit <https://cadin360.com/contact-us/>.

Customer feedback is critical to our efforts at CADIN360.

Best regards,

Sachidanand Jha
Founder & CEO, CADIN360



AUTODESK FUSION 360 ALL IN ONE WORKBOOK

Published by CADIN360

Website: cadin360.com

Copyright © 2025 by CADIN360, All rights reserved.

This book is copyrighted and the CADIN360 reserves all rights.

No part of this publication may be reproduced, stored in a retrieval system or transmitted, transcribed, stored in retrieval system or translated into any language, in any form or by any means, electronic, mechanical, photocopying, recording, scanning or otherwise, without the prior written permission of the publisher & Author.

Limit of Liability/Disclaimer of Warranty:

The publisher and the author make no representations or warranties with respect to the accuracy or completeness of the contents of this work and specifically disclaim all warranties, including without limitation warranties of fitness for a particular purpose. No warranty may be created or extended by sales or promotional materials. The advice and strategies contained herein may not be suitable for every situation. This work is sold with the understanding that the publisher is not engaged in rendering legal, accounting, or other professional services. If professional assistance is required, the services of a competent professional person should be sought. Neither the publisher nor the author shall be liable for damages arising herefrom. The fact that an organization or Web site is referred to in this work as a citation and/or a potential source of further information does not mean that the author or the publisher endorses the information the organization or Web site may provide or recommendations it may make. Further, readers should be aware that Internet Web sites listed in this work may have changed or disappeared between when this work was written and when it is read.

Examination Copies

Books received as examination copies in any form such as paperback and eBook are for review only and may not be made available for the use of the student. These files may not be transferred to any other party. Resale of examination copies is prohibited

Electronic Files & Usage Rights:

The electronic file/eBook in any form of this book is licensed to the original user only and may not be shared, distributed, resale or transferred to any other party. To access files, the user must contact **cadin360@gmail.com** with valid proof of purchase. Unauthorized distribution of the files is a violation of copyright law.

Disclaimer:

All product names, logos, brands, and registered trademarks mentioned in this publication are the property of their respective owners and are used for identification purposes only.

AUTODESK FUSION 360 ALL IN ONE WORKBOOK

- ❖ This book contains over 500 CAD practice exercises, organized as:
 1. 200 2D Sketching Exercises
 2. 200 3D Modeling Exercises
 3. Assembly Projects with 150+ Part Drawings
- ❖ This book is a practice workbook. It does not include step-by-step tutorials for creating 2D drawing, 3D models and Assembly.
- ❖ SI units (millimeters) are used for all dimensions.
- ❖ Third Angle Projection is used throughout this book.
- ❖ This book is for **AUTODESK FUSION 360** and also suitable for Other Feature-Based Modeling Software such as Inventor, Catia, SolidWorks, NX, Solid Edge, AutoCAD, PTC Creo etc.
- ❖ Designed for students, engineers, drafters, and designers looking for extensive CAD practice using Autodesk Fusion 360.
- ❖ The exercises cover a wide range of real-world modeling challenges—from simple sketches to complex assemblies—offering clear, concise, and structured drawing practice.
- ❖ Exercises are organized to gradually develop beginner to advanced-level design skills.
- ❖ Each exercise is self-contained, and can be completed independently.
- ❖ Assembly drawings follow industry standards to help improve visualization and multi-part modeling skills.
- ❖ All dimensions are in mm. Assume missing dimensions logically.

HOW TO USE THIS BOOK

This book contains over 500 CAD practice exercises, designed for self-paced learning using Autodesk Fusion 360 or any feature-based modeling software.

- 2D Sketching Exercises: Start here if you're a beginner or learning how to use the sketch environment.
- 3D Modeling Exercises: Follow after mastering sketching. Practice creating solid models using the provided dimensions.
- Assembly Drawings: Use after completing part models to understand multi-part assemblies, relationships, and constraints.

Tips for Best Use:

- Complete the exercises in order, or jump to any skill level you prefer.
- All dimensions are in millimeters.
- Where dimensions are missing, apply logic or practice estimation.
- This book is ideal for both students and professionals preparing for industry design work.

Note:

This book is available in multiple formats – **Black & White**, **Standard Color**, and **Premium Color** editions.

Happy learning!
– Team CADIN360

3D

EXERCISE-01

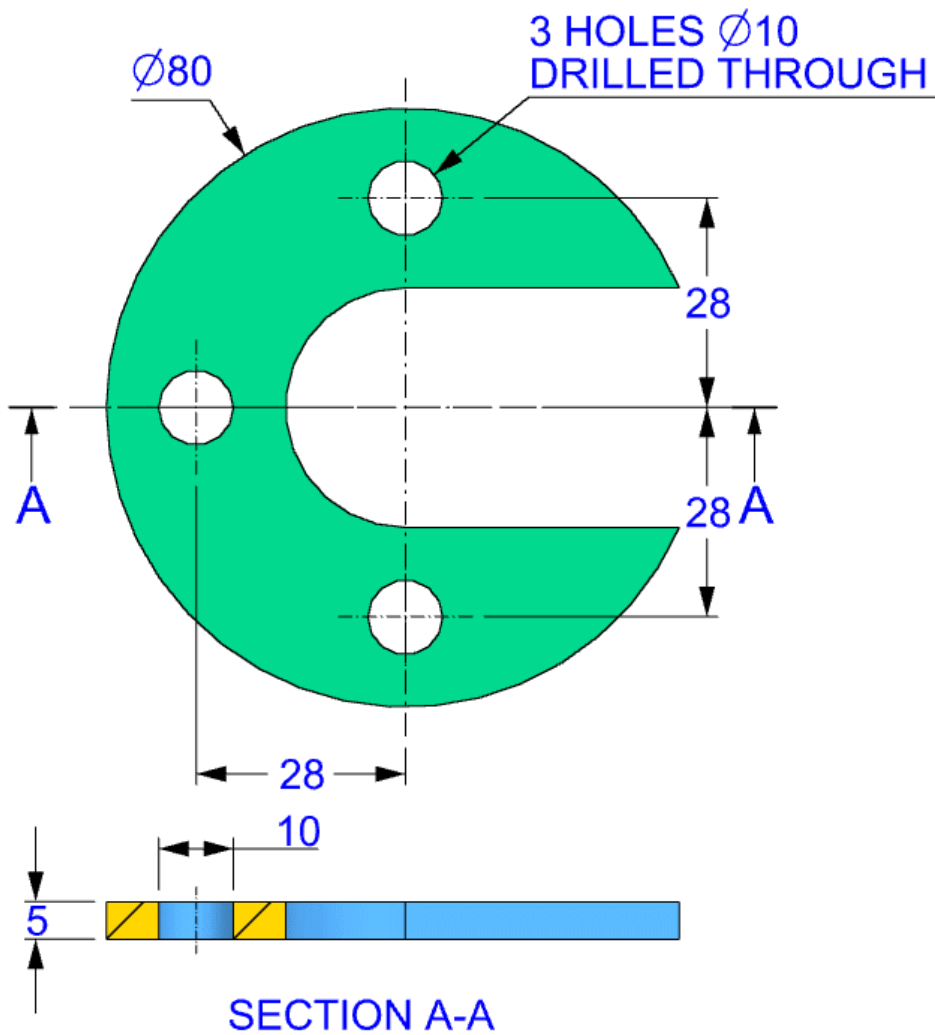
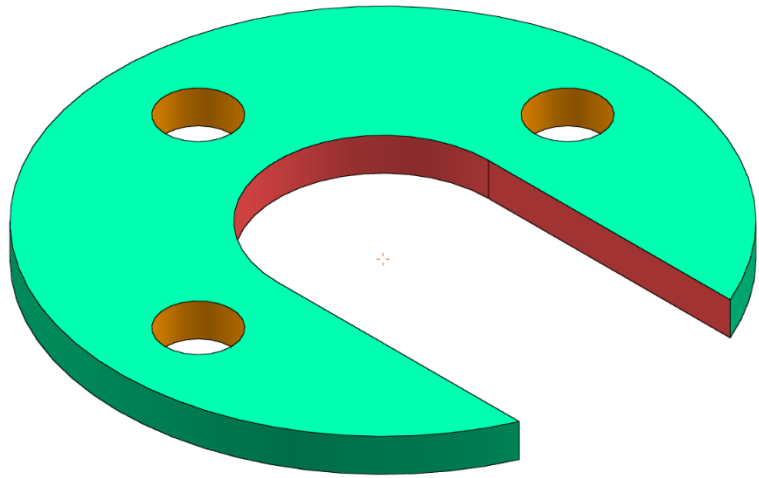

Get The Complete Practice Sample

You downloaded a single Exercise PDF

The complete practice sample for this software includes multiple exercises and is not available inside this PDF..

What you will receive

- A software-specific complete sample PDF
- Multiple real practice exercises (not a single file)
- Same quality as our professional training material
- Compatible with the latest software version

How to get the complete sample

Click the button below and **enter a valid email address**. The **complete sample PDF will be delivered automatically** after the form is submitted.

SEND THE COMPLETE SAMPLE TO MY EMAIL

END OF SAMPLE

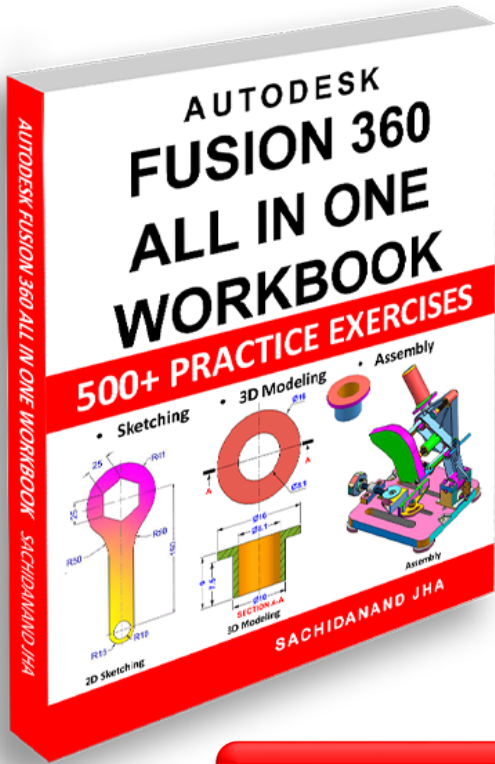

What's Included in the FUSION 360 ALL IN ONE WORKBOOK?

- ✓ Books contains exercises of Sketching, 3D Modeling & Assembly.
- ✓ 500+ Practice Exercises with Dimensions
- ✓ Full Assembly STEP Files (.stp format) – Compatible with all major CAD software
- ✓ Get 200 3D Exercises in .f3d file format
- ✓ Get All Assembly Exercises in .STP file
- ✓ Instant Download Link - Sent to Your Email After Payment
- ✓ Lifetime Access to All Files

Get the Paperback book on Amazon

Get the Complete Bundle for Only \$27.99

Special Offer for Students & Learners

Are you a Student, Unemployed or Financially struggling ?
Get this special Bundle only for \$19.99

Special Offer for Only \$19.99



Thank You for Learning with Us!

Thank you for choosing the **AutoDesk Fusion 360 ALL IN ONE WORKBOOK**. We hope this book helped you strengthen your Fusion 360 skills through hands-on practice and real-world design challenges.

Your feedback means the world to us!

If you found this book helpful, please take a moment to leave a **review** on the Amazon where you purchased it. Your kind words not only motivate us but also help other learners discover our resources. Scan the QR.

★ A good review goes a long way!

📖 Explore More CAD Practice Books

Looking to continue your learning journey?

We offer similar practice-based books for over **30 CAD software platforms**, including:

- AutoCAD
- SolidWorks
- FreeCAD
- TinkerCAD
- TurboCAD
- Siemens NX
- CATIA
- Creo
- SketchUp and many more...

Visit our website 🖱️ www.cadin360.com to browse the complete collection.

💬 Stay Connected

Have suggestions, feedback, or just want to say hello?

We'd love to hear from you!

✉️ Email: cadin360@gmail.com

🌐 Website: www.cadin360.com

🚀 Keep Practicing. Keep Designing.

Whether you're a beginner or a pro, **practice is the key** to mastering any CAD software.

We're honored to be a part of your journey.

Happy Designing!

– Team **Cadin360**



Master Fusion 360 with Real-World Practice Exercises

This book contains over 500 Fusion 360 practice exercises including sketching, 3D modeling, and assembly drawings.

Designed for students, engineers, and professionals to build practical CAD modeling skills.

AUTODESK FUSION 360 ALL IN ONE WORKBOOK

This book contains:-

- 200 2D Sketching Exercises
- 200 3D Modeling Exercises
- Multi-part Assembly Exercises & Detailed Drawings
- All drawings in 3rd Angle projection
- All dimensions are in mm(metric system)